





Case Studies on the Integration of Renewable Energy Sources into Power Systems

R. Belhomme



1 10/11/2005

Kasseler Symposium, R. Belhomme

1 Introduction

11 case studies :

- DISPOWER European project : Distributed generation with high penetration of renewable energy sources (Contract No. ENK5-CT-2001-00522)
- Objectives :
 - To apply tools and concepts developed in DISPOWER on national, regional or local power systems in different European countries
 - To demonstrate implementation of DG and RES technology on interconnected grids and on island power systems
 - To contribute to the dissemination and exploitation of the results of DISPOWER

2

10/11/2005

Kasseler Symposium, R. Belhomme

1 Introduction (2)

5 case studies on interconnected grids :

- Germany (2), France, Spain, Austria

6 case studies on weak grids and island power systems

- United Kingdom (3), Greece (Crete and Kythnos islands) (2), and the French West Indies (Les Saintes islands)

11 partners from 6 different countries

Two DISPOWER Deliverables :

- Distributed generation on European interconnected grids
- Distributed generation on European islands and weak grids

Summary of work done and results



3

10/11/2005

Kasseler Symposium, R. Belhomme



2 Wind generation on German interconnected grid (ISET)

Wind power in Germany

- End of 2004 : > 16000 MW
- ~ 15 % peak load
- Increase of uncontrollable and highly variable generation
=> increase of
 - uncertainty in power system
 - reserves

Needs for :

- Online monitoring of wind power generation
- "reliable" wind power prediction
- Taking wind power into account in system planning



4

10/11/2005

Kasseler Symposium, R. Belhomme



2 Wind generation on German interconnected grid (ISET) (2)

Wind Power Management System (WPMS)

- WP control center to support large-scale integration of WP

Online-monitoring of WP generation

- Representative WTs
- Control areas, regions

Day-ahead forecast

- Up to 72hours in advance

Short- term prediction

=> Application to German interconnected grid

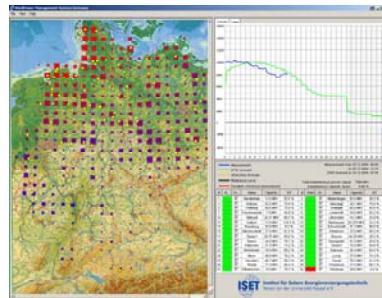

5



10/11/2005

Kasseler Symposium, R. Belhomme



3 Advanced Grid Control Unit for DG Integration into German grid (University Kassel)

Advanced Grid Control Unit (AGCU)

- Web-based SCADA system
- Objectives :
 - Monitor, maintain and control « DG-farms » online from anywhere at any time
 - Optimize « DG-farm » operation according to grid requirements and economical aspects
- One main DG-Farm server & multiple dispersed plant controllers (one par DG)
- Details of design & implementation in DISPOWER Deliverable 7.2

6



10/11/2005

Kasseler Symposium, R. Belhomme



3 Advanced Grid Control Unit for DG Integration into German grid (University Kassel) (2)

Application at test site in Friedland-Deiderode :

- 4 WTGs and one CHP

Results

- Works satisfactorily
- Feasibility of remote monitoring and control
- But not possible to test effective control of WTGs (legal aspects not owner)

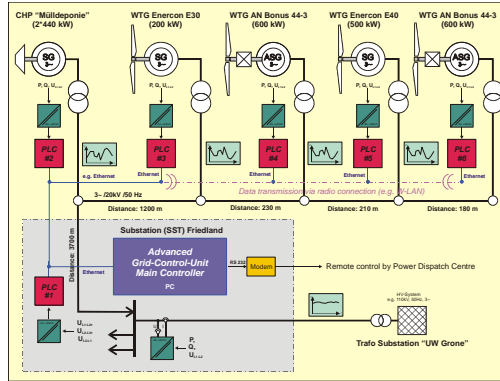

7



10/11/2005

Kasseler Symposium, R. Belhomme



4 Wind generation on French interconnected grid (EDF)

Impact of high WP penetration on the French interconnected grid

- Dynamic point of view : voltage dips and frequency variations

3 scenarios for WP development in France :

- In France at end of October 2005 : ~ 560 MW installed WP

	Moderate	Sustained	Voluntary
2010	2 000 MW (4.5%)	6 000 MW	10 000 MW (22%)
2015	5 000 MW (10 %)	10 000 MW	16 000 MW (32%)
2020	8 000 MW (15%)	15 000 MW	22 000 MW (40%)

N.B. Scenarios developed on purpose for this DISPOWER case study by EDF R&D

8



10/11/2005

Kasseler Symposium, R. Belhomme



4 Wind generation on French interconnected grid (EDF) (2)

Simulation (EUROSTAG software):

- Minimum grid reinforcements
- Short-circuits 400 kV, 225kV
- Loss of generation
- Different wind turbine technologies

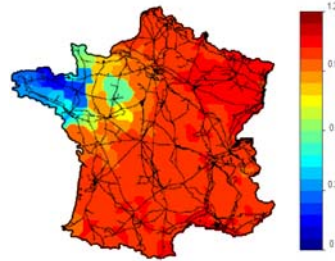

Results :

- Worst case : 1/6th France $V < 0.85$ pu, 1/8th France $V < 0.75$ pu
- Voltage regulation : affected WP much reduced (< 3000 MW)
- But disconnected WP depends on protection scheme
=> FRT capabilities limit disconnected WP

With appropriate V regulation & protection scheme with FRT capabilities, risk of loosing > 3000 MW is avoided (UCTE event)



9

10/11/2005

Kasseler Symposium, R. Belhomme



5 Distributed generation in Spain (EHN, Iberdrola Distribution)

Overview of electric power system in Navarra

- Grid, demand and generation
- DG & RES technologies
- Grid connection requirements

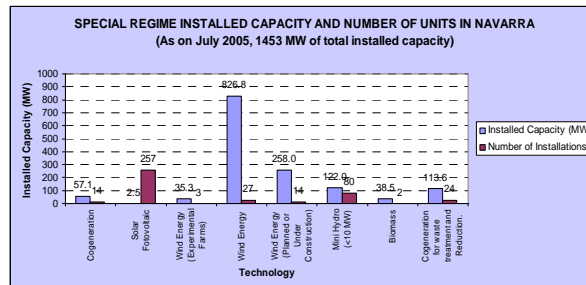

10

10/11/2005

Kasseler Symposium, R. Belhomme



5 Distributed generation in Spain (EHN, Iberdrola Distribution) (2)

Impact on power system :

- Overview of the changes required : transformers, lines, ...
- Network operation : daily operation and daily planning of energy consumption

Increasing DG&RES penetration : 3 scenarios (2005, 2007, 2011)

- Load flow studies

Ancillary services provision

- Reactive power and voltage control
- Solution developed by EHN under test at Alaiz wind farm
- First results show feasibility and security of the method.

11



10/11/2005

Kasseler Symposium, R. Belhomme



6 Distributed generation from renewables in Austria (Verbundplan)

Development of a planning method for design of DG network :

- Adaptation and combination of planning tools with other software
- General base: data, parameters of the study, ...
- Geographical information
- Network design: load flow, dynamic behavior, islanded operation,...
- Financial analysis
- Final decision



12



10/11/2005

Kasseler Symposium, R. Belhomme



6 Distributed generation from renewables in Austria (Verbundplan) (2)

Alpine Valley case study

- Alpine valley in Salzburg region
- Presently : small Hydro power plants
- Long MV feeder
- Additional DG : Hydro plants, Wind turbines, biomass, PV,..
 - potentials for each type separately
 - Potentials for a combination of different DG types
 - Economic comparison

National wind power case study

- Possibilities to integrate up to 1 GW wind power in Austria
- Impact on the power system

13



10/11/2005

Kasseler Symposium, R. Belhomme



7 Increased wind energy penetration on weak networks in rural northern England (Econnect)

Use of load management to enable increased wind power penetration on weak networks

- Computer simulation
- Haydon feeder, rural region in North East of England
- No load control : limited to 300 kW wind power due to voltage rise
- 50 % load control : 1.5 MW
- 20 % load control (more realistic) : 900 kW

⇒ Load control allows to increase WP penetration

⇒ effective strategy to mitigate voltage rise.

14



10/11/2005

Kasseler Symposium, R. Belhomme



8 Diesel / hydro generation on Scottish Island of Rum (Econnect)

Load management schemes to improve availability of the power system

- Modelling of the existing power system
 - Computer simulation with new control concepts :
 - Distributed Intelligent Load Controllers (DILC)
 - Feasibility of frequency control between acceptable limits
 - Not as refined as existing controller
 - Extensive programme of site testing with DILC
 - Larger voltage changes than anticipated
 - Due to loads very different in size : 250 W -> 7.5 kW
 - ⇒ Different switching actions have very different effects
- ⇒ further work needed on DILC for binary load control

15



10/11/2005

Kasseler Symposium, R. Belhomme



9 Islanded operation of a wind farm in the UK (Econnect)

Use of synchronous compensator & load control for power quality and stability in islanded operation of a wind farm

- Wind farm with 300 kW pitch regulated WTGs
- Design of a synchronous compensator and load control strategy :
 - Requirements for islanded operation of the site : voltage & frequency, protection, overload, maximum use of WP, ...
- Computer model and simulations show the feasibility
- Test on site :
 - Equipment purchased, installed, tested ... decommissioned
 - Feasibility of voltage and frequency control between acceptable limits
 - Problems of turbine start up in certain conditions

16



10/11/2005

Kasseler Symposium, R. Belhomme



10 Concepts for high penetration of RES on Greek Islands (ICCS, CRES)

Application of MORE CARE control system on Crete and Kythnos islands

- Evaluation of the functions of MORE CARE : economic scheduling, forecasting, on-line dynamic security assessment, ...

Kythnos

- Diesel, wind, PV : annual RES penetration 11% (40% for > 1000h)
- Operating costs reduced by :
 - 2.63 % with improved RES & load forecasting
 - 0.8 % with new economic dispatch functions
 - 2.16 % with energy storage in economic scheduling while maintaining a high level of security in the power system
 - ...

17



10/11/2005

Kasseler Symposium, R. Belhomme



10 Concepts for high penetration of RES on Greek Islands (ICCS, CRES) (2)

Crete

- Operating costs reduction of 8.5 % due to improvement of forecast errors
- Gains :
 - From 3.1 % to 6 % due to economic scheduling functions
 - From 1.7 % to 2.7 % due to economic dispatch
- 95% success in assessing insecure operating points
- Off-line evaluation of WP impact on economic operation:
 - annual savings of 1.45%

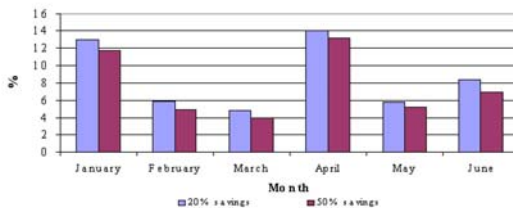

18



10/11/2005

Kasseler Symposium, R. Belhomme



11 Interconnection of Solar Powered Mini-Grids to main grid on Kythnos (CRES, Econnect, ISET)

Interconnection issues for increased penetration of RES

- Voltage profile, P & Q flows, thermal loading, V & Q control, frequency control, ...

Steady-state study

- PSSE & Tool developed by CRES based on GIS
- PV and wind turbine at various points
- Voltage profile within the limits
- Thermal loading also
- V improved in heavy load conditions

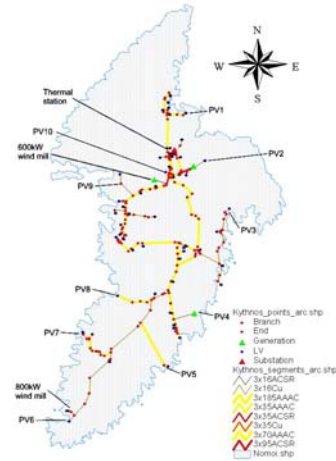

19



10/11/2005

Kasseler Symposium, R. Belhomme



11 Interconnection of Solar Powered Mini-Grids to main grid on Kythnos (CRES, Econnect, ISET)(2)

Dynamic stability study

- Computer model of Diesel, WTG, PV, and battery storage
- Three-phase short-circuits and disconnection of WTG
- Results for PV scenarios :
 - stable behavior if adequate spinning reserve
 - But expensive with diesel gensets
 - Two solutions : PV with FRT capability or battery energy storage
- Results for WTG scenario :
 - Stable behavior
- Frequency control improved with battery energy storage

20



10/11/2005

Kasseler Symposium, R. Belhomme



12 Renewable energies in Les Saintes islands (Vergnet, ENSMP-CENERG, Uni Kassel, ISET, EDF)

Grid connection of a 2MW wind farm

- Les Saintes connected by subsea cable to Guadeloupe
- Main problems identified :
 - Voltage rise
 - High flicker level
- Different solutions have been studied or discussed :
 - Grid reinforcement
 - Different strategies for voltage or Q control
 - Change wind turbine technology
 - Additional equipment : STATCOM, load control, ...
 - Power curtailment

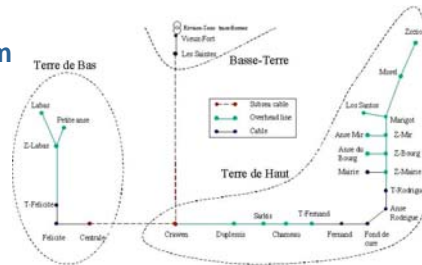

21



10/11/2005

Kasseler Symposium, R. Belhomme



12 Renewable energies in Les Saintes islands (Vergnet, ENSMP-CENERG, Uni Kassel, ISET, EDF) (2)

- Potential of GIS tools :
 - Study various load development or DG impact scenarios
 - Better understand the grid behaviour
 - Devise a complete decision tool
- Loss of the subsea cable :
 - Wind/diesel operation with wind power penetration limited and appropriate coordinated control strategy would be needed
 - But very heavy modifications would be required to existing system
 - Other solutions : load control, energy storage, ...

22



10/11/2005

Kasseler Symposium, R. Belhomme



13 Conclusions

11 case studies but for 4 main types

- Development, implementation and/or assessment of monitoring and control systems :
 - Wind power control center (WPMS)
 - Web-based SCADA system for « Farms » of DG and RES plants (AGCU)
 - Application of MORE CARE control software
- Impacts of increased DG and RES penetration on interconnected and island grids :
 - Importance of voltage and Q control, and FRT capabilities
 - Importance of frequency control on island grids
 - Solutions for different issues : voltage rise, flicker, stability, ... in particular, energy storage, use of PE interfaces, ...

23



10/11/2005

Kasseler Symposium, R. Belhomme



13 Conclusions (2)

- Load management :
 - To increase RES (WP) penetration on weak grids
 - With DILC for frequency control on an island grid
 - Combined with synchronous compensator for islanded operation of a wind farm
- Tools and planning approaches for networks with DG :
 - GIS tools
 - Combination of planning tools for global approach taking technical, economic, and environmental aspects into account

Very promising and interesting results :

- Feasibility of approaches and concepts developed in DISPOWER

But still a lot of work to be done ...

24



10/11/2005

Kasseler Symposium, R. Belhomme



14 Contact information

EDF: R. Belhomme, P. Bousseau, regine.belhomme@edf.fr, pierre.bousseau@edf.fr

Iberdrola Distribution : E. Navarro, enavarro@iberdrola.es

ISSET : A. Badelin, T. Degner, abadelin@iset.uni-kassel.de, tdegner@iset.uni-kassel.de

University Kassel : G. Arnold, garnold@iset.uni-kassel.de

CEHN: A. Berenguer, I. Chocarro, aberenguer@ehn.es, ichocarro@ehn.es

Verbundplan : C. Materazzi-Wagner, christine.materazzi@verbundplan.at

Econnect : S. White, Sara.White@econnect.co.uk

ICCS : N. Hatziargyriou, nh@power.ece.ntua.gr

CRES : S. Tselepis, Aristomenis Neris, stselep@cres.gr, mneris@cres.gr

Vergnet : D. Lefebvre, d.lefebvre@vergnnet.fr

ENSMP-CENERG : T. Ranchin, thierry.ranchin@ensmp.fr

